

# Pump Adhesives & Sealants

Permabond adhesives and sealants are used to lock fasteners, form gaskets, bond 'o' rings, and retain pins in various pumps used in many different industries. If you don't see your pump application here please contact us.

## Automobile Pumps

*Applications: Threadlocking, Gasketing, Retaining, Bonding, Sealing Fuel Pumps*

■ Reduce noise and maintain optimal gas mileage by securing the seal of the fuel system.



Permabond HM129 a high strength threadlocker, locks and seals studs in the pump. Permabond A126, wicking grade anaerobic sealant, seals and locks the inlet and outlet tubes. The pipe unions and fuel tank sender are sealed with medium strength threadlocker, Permabond A1042.

All three of these products prevent loosening due to vibration.

The fuel pump gasket is sealed with a flexible form in place gasket material, Permabond MH199.

- Environmentally friendly
- Non-flammable
- 100% solids
- Application process can be easily automated
- Fluoresce under UV black light for easy QC inspection
- Excellent resistance to water, oil, fuel and other chemicals

*Applications: Threadlocking, Gasketing, Retaining, Bonding, Sealing Oil Pumps*



Permabond removable threadlockers are used throughout the pump to secure the threaded fasteners and seal plugs.

Permabond retaining compound, HM162 is used to retain the drive pinion and the alignment pin.

## Industrial Vacuum Pump

*Application: Bonding O-rings*

■ Secure o-rings to ensure they stay in place prior to installation.

Permabond cyanoacrylates quickly bond o-rings to pumps. Eliminating lost o-rings reduces call backs, leaks and frustrations.

- Rapid-curing
- Non-flammable
- 100% solids
- Easy application process
- Good adhesion to metals & rubber
- Single-part so no weighing or mixing required

*Adhesive used: Permabond 102*

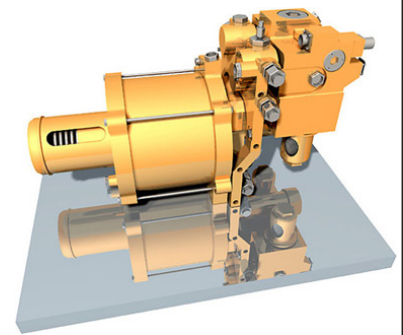

## Oxygen Pumps

*Application: Threadsealing connections*

■ Sealed connections increase pump efficiency

Permabond thread sealant is BAM approved for use with gaseous oxygen up to 10 bar (145 psi) and provides a complete seal on metal threaded connections.

*Adhesive used: Permabond MH052*



# Permabond®

Engineering Adhesives

## Pump Applications

Product	Description	Typical Applications	Availability
MM115	Anaerobic, Blue, Removable Threadlocker	Locking threaded fasteners and seal plugs	Americas & Asia
A1042	Anaerobic, Blue Removable Threadlocker	Locking threaded fasteners and seal plugs	Europe, Middle East, Australia
HM129	Anaerobic, Red, Permanent Threadlocker	Permanently locking threaded fasteners	Worldwide
MH199	Anaerobic, Red, Form-in-Place Gasket	Form in place gasket	Worldwide
102	Cyanoacrylate, Clear, Instant Adhesive	Bonding 'o' rings & Threadlocking plastic bolts	Worldwide
LH050 PURE	Anaerobic, White, NSF/ANSI 61 Certified Thread Sealant	Sealing threads in potable water contact applications	Americas & Asia
LH050	Anaerobic, White, Thread Sealant	Thread sealing	Americas & Asia
A131	Anaerobic, White, Thread Sealant	Thread sealing	Europe, Middle East, Australia
MM115 PURE	Anaerobic, Colorless, NSF/ANSI 61 Certified Removable Threadlocker	Locking bolts in potable water contact applications	Americas & Asia
MH052	Anaerobic, Medium strength thread sealant approved for use with gaseous oxygen to 10 bar (145 psi).	Thread sealing coarse threads & threads in contact with gaseous oxygen.	Worldwide
HM162	Anaerobic, Green, Retaining Compound	Retaining pins	Worldwide

## Contact US

[www.permabond.com](http://www.permabond.com)

- **US Helpline - 800-640-7599**
- **UK - 0800 975 9800**
- **Asia + 86 21 5773 4913**
- **Americas +1 732 868 1372**
- **General Enquiries +44(0)1962 711661**
- **Deutschland 0800 101 3177**
- **France 0805 111 388**

[info.europe@permabond.com](mailto:info.europe@permabond.com)

[info.americas@permabond.com](mailto:info.americas@permabond.com)

[info.asia@permabond.com](mailto:info.asia@permabond.com)

The experienced team of Permabond chemists is on hand to help you with custom formulations and fulfilling your technical data requests.



Permabond's sales engineers are available to assess your production line and find the best possible turnkey adhesive solution that will result in production efficiencies.



### Permabond Worldwide

Wherever your manufacturing or R&D site may be located, Permabond representatives can be called upon to assist you. We have an extensive network of trained distributors worldwide.

Non-warranty: The information given and the recommendations made herein are based on our research and are believed to be accurate but no guarantee of their accuracy is made. In every case we urge and recommend that purchasers before using any product in full scale production make their own tests to determine to their own satisfaction whether the product is of acceptable quality and is suitable for their particular purposes under their own operating conditions. No representative of ours has any authority to waive or change the foregoing provisions but, subject to such provisions, our engineers are available to assist purchasers in adapting our products to their needs and to the circumstances prevailing in their business. Nothing contained herein shall be construed to imply the nonexistence of any relevant patents or to constitute a permission, inducement or recommendation to practice any invention covered by any patent, without authority from the owner of this patent. We also expect purchasers to use our products in accordance with the guiding principle of the Chemical Manufacturers Association's Responsible Care® program.